

INSTALLATION INSTRUCTIONS

Step 1: Remove Existing Fan & Shroud

Separate radiator overflow bottle from shroud and set aside. This will be installed with a new shroud.

Step 2: Mount overflow bottle

Mount bracket number 35234 to left side of shroud.

Step 3: Mount bottom brackets

Mount spacer and bottom bracket number 35235 to the bottom of the shroud. Leave brackets loose for adjustment. Use the 2 long allen head screws provided.

Step 4: Mount top bracket with inserts

Mount bracket number 35233 to top of shroud.

Step 5: Mount top bracket

Mount top bracket number 35232 to inserts of bracket 35233. Leave loose for adjustment.

Step 6: Locate mounting point for control

Locate a mounting point for control near passenger side of radiator. Control needs to be placed within 18" of radiator inlet hose on passenger side. You may want to mount next to radiator on fender well or the corner of the fan shroud. Mount control using screws provided

Step 7: Wire fan

Route motor wires through shroud, you may drill a 1/4" hole and pass the wires through.

Step 8: Mount fan assembly

Mount fan assembly and tighten brackets. Adjust brackets to seal shroud to radiator core.

Put the fan into place. Before tightening the brackets, adjust the fan so that the rubber seal is contacting the radiator core and compress the seal about 50%. It may help to have a friend hold the fan against the core while tightening brackets.

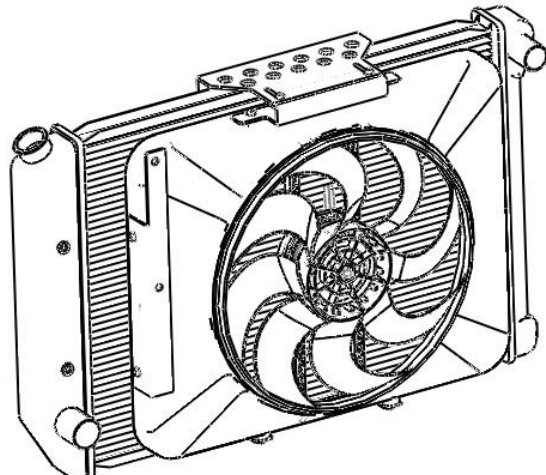

Step 9: Mount overflow bottle

Mount overflow bottle to bracket using bolts and large washers provided.

Step 10: Wire the fan motors (refer to Wiring Diagram, below)

Using the yellow butt connectors provided, attach a length of the large diameter (10 AWG) red wire to the blue motor wire. Attach a length of the large diameter (10 AWG) black wire to the black motor wire. Once the fan is in place, these will attach to the control module. **Tip: Strip an additional 1/8" of insulation from the motor wires and fold them over to increase the thickness of the wire where it will slide into the butt connector.** If mounting the control module to the fan shroud, the motor wires can be connected now (see wiring diagram, next page). If mounting the control somewhere else in the engine compartment, leave enough wire to reach the control module, but do not connect yet.

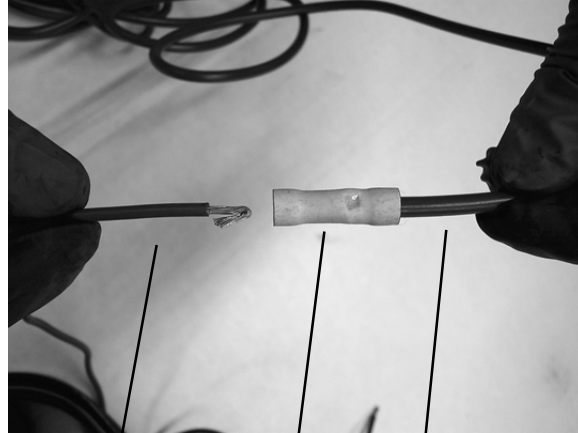

Crimp the motor wires to the large supplied wire...

Blue motor wire

Large dia. red wire

Yellow butt connector

Step 11: Wire the control module

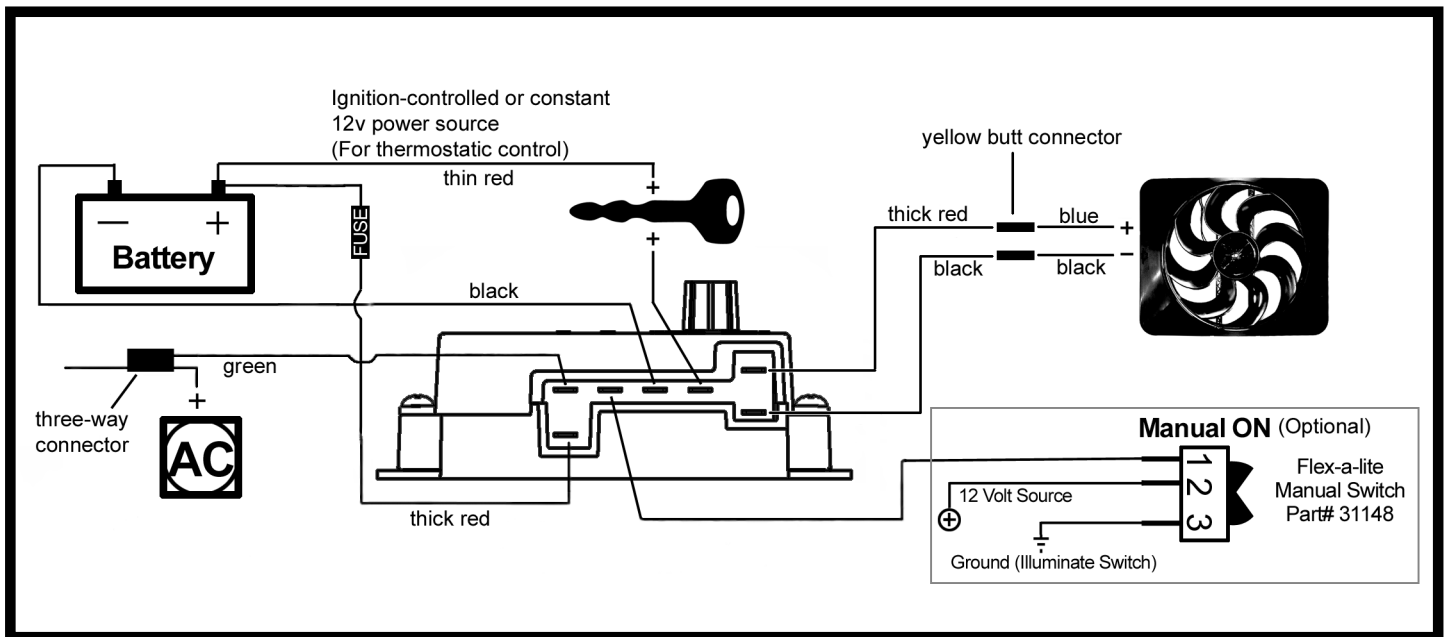

11a. Connect the motor wires to the control module (Red wire to the "M+" terminal and black wire to the "M-" terminal).

11b. Disconnect the negative battery lead for safety while finishing the wiring. Use the large diameter red (10 AWG) wire to run power directly from the battery positive (+) terminal to the "B" terminal on the control module. Connect the fuse holder in-line with this wire, as shown, but do not insert the fuse yet. Use the yellow female, ring, and butt connectors provided.

CONTINUE TO NEXT PAGE TO COMPLETE THE INSTALLATION.

11c. Use the large diameter black (10 AWG) wire to run from the negative (-) battery terminal to the "G" terminal on the control module. Use the yellow female connector and ring connector provided.

11d. Use the small diameter red wire (14 AWG) to connect the "+" terminal on the control module to a positive power source. **NOTE: Attaching this wire to an ignition-controlled source will shut off the fan when the engine is turned off. Attach this wire to an uninterrupted (always hot) power source to allow the fan to continue running after the engine is shut off.** Use the blue female connector and fuse taps (included) if necessary.

11e. (Optional) For air conditioning control (if desired) connect the "C" terminal on the control module to the *positive* wire that triggers the A/C compressor using the small diameter green (14 AWG) wire. Using a voltmeter, determine which wire coming from the compressor is the *positive* trigger wire. Use the 3-way connector (included) to tap into this wire and send a signal to the fan control module. The fan will cycle on and off with the A/C clutch when the A/C is turned on.

11f. (Optional) For manual switch operation, use Flex-a-lite p/n 31148. Connect the switch as shown on the wiring diagram (previous page). Connect the "M" terminal on the control module to the "1" terminal on the switch. Connect the "2" terminal on the switch to a positive 12v power source. Connect terminal "3" on the switch to a good ground (for switch illumination). **NOTE: To prevent thermostatic activation (if only manual switch operation is desired), omit the lead to the "+" terminal of the control box. "B", "G", "M+" and "M-" must remain connected. If not using a Flex-a-lite manual switch, do not connect a ground wire to the switch!**

11g. Use the zip ties provided to secure the wires and prevent them from interfering with fan blades, belts, and pulleys in the engine compartment. Reconnect the battery and insert the fuse provided.

Step 12: Insert the temperature probe into the radiator fins



Install temp. probe near inlet hose...

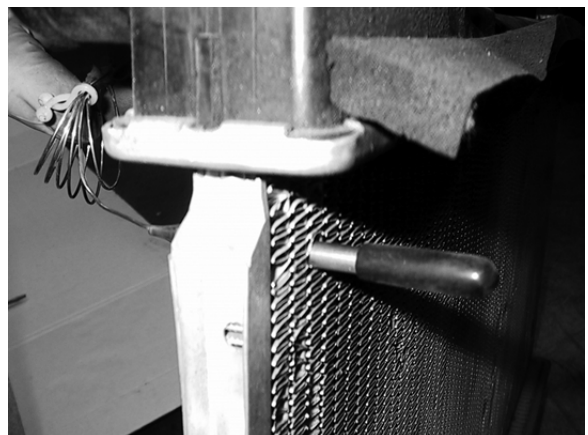

then replace the insulator cap.

Locate the inlet hose from the engine to the radiator. Remove the black insulator cap and insert the temp. probe through the radiator fins near the inlet hose. Reinstall the black insulator cap.

Step 13: Adjust the temperature control knob on the control box

If you disconnected any hoses or drained coolant to install the fan, reconnect the hoses and refill the radiator. Press the control knob (included in wiring kit) onto the control box shaft. Turn the knob clockwise until it stops. Start the engine and allow it to idle. Using a hand held thermometer (positioned near the inlet hose) or the vehicle's temperature gauge, monitor the temperature. When the coolant temp. is slightly above normal (or desired temp.), turn the knob counter-clockwise just until the fan turns on. From now on, the fan should activate at this temperature setting. Adjust as necessary to maintain desired temperature.

The Flex-a-lite Limited Warranty

Flex-a-lite Consolidated, 7213-45th St. Ct. E. Fife, WA 98424, Telephone No. 253-922-2700, warrants to the original purchasing user, that all Flex-a-lite products to be free of defects in material and workmanship for a period of 365 days (1 year) from date of purchase. Flex-a-lite products failing within 365 days (1 year) from date of purchase may be returned to the factory through the point of purchase, transportation charges prepaid. If, on inspection, cause of failure is determined to be defective material or workmanship and not by misuse, accidental or improper installation, Flex-a-lite will replace the fan free of charge, transportation prepaid. **Flex-a-lite will not be liable for incidental, progressive or consequential damages.** Some states do not allow the exclusion or limitation of incidental or consequential damages, so the above limitation or exclusion may not apply to you. This warranty gives you specific legal rights and you may have other rights, which vary from state to state. The Flex-a-lite warranty is in compliance with the Magnuson-Moss Warranty Act of 1975.